

OSTROŻNIE! SZKŁO HARTOWANE!

Szkło hartowane jest dużo bardziej odporne na zginanie i zmiany temperatur niż tradycyjne. Jest to szkło bezpieczne, gdyż po przekroczeniu jego wytrzymałości ulega rozbiciu na wiele drobnych kawałków, co minimalizuje ryzyko poważniejszego zranienia. Uszkodzona krawędź, zarysowanie powierzchni bądź zbyt silne naprężenie (np. spowodowane nieprawidłowym montażem) może spowodować rozbicie szyby (popękanie). W zależności od wielkości ubytku lub siły naprężenia może to nastąpić bezpośrednio przy montażu bądź nawet po kilku miesiącach. Podczas montażu kabiny szczególnie należy dbać o to, aby krawędzie tafli szkła nie stykały się bezpośrednio z twardymi powierzchniami (np. nie należy opierać tafli szkła na kaflach- szczególnie narożników - podczas montażu). Krawędzie szkła powinny być zabezpieczone ochronnymi narożnikami lub osłonami z tworzywa sztucznego w trakcie wyjmowania z opakowania oraz montażu.

BK251

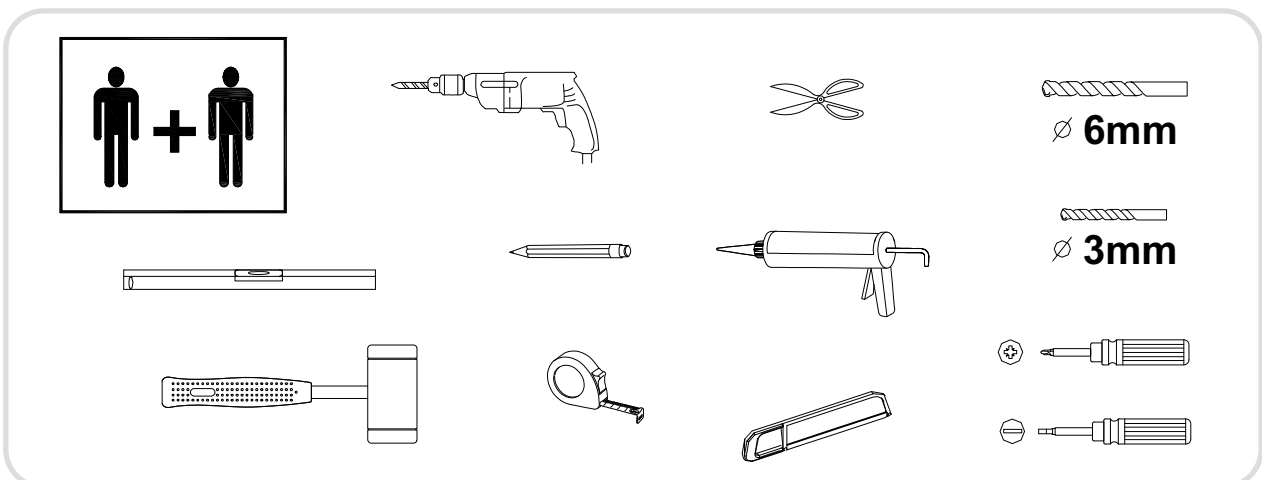

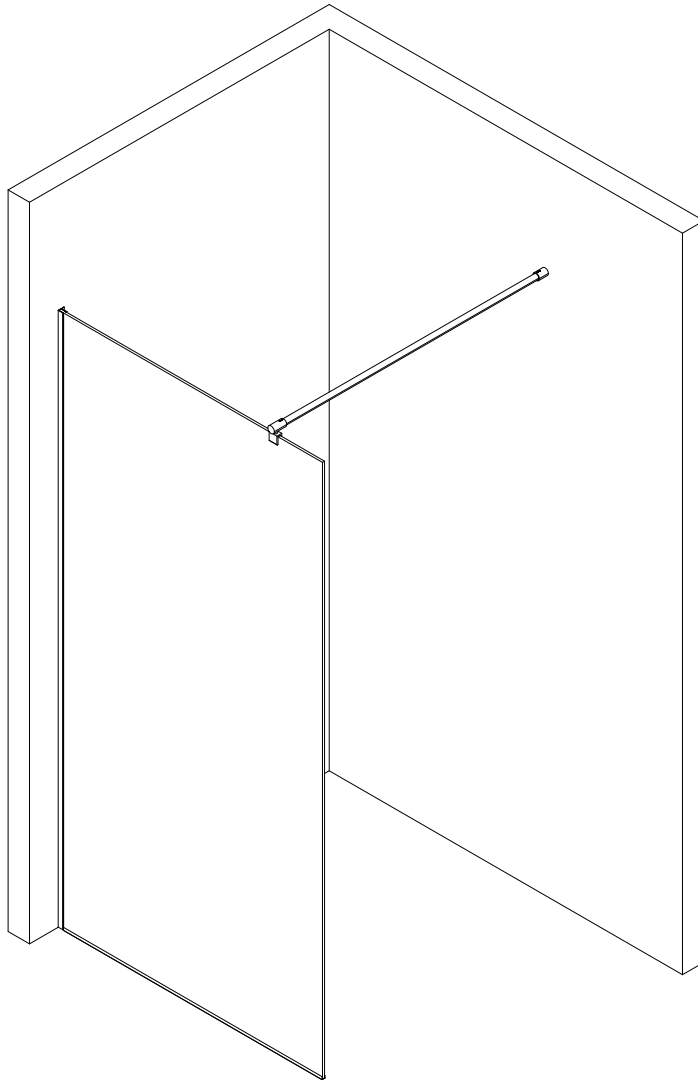
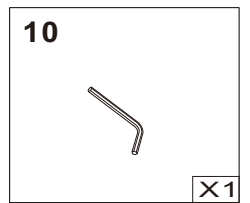
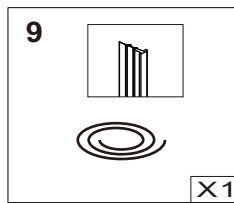
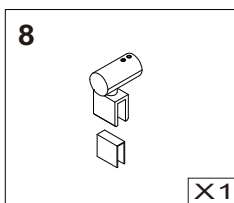
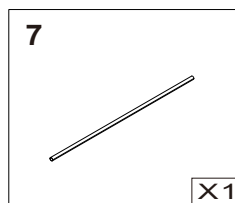
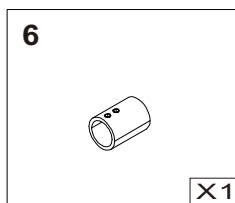
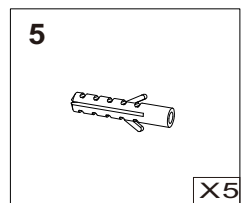
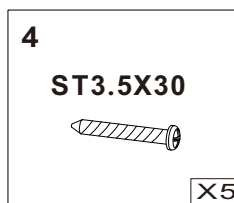
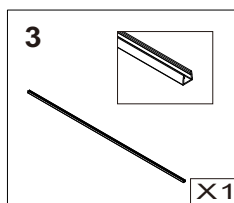
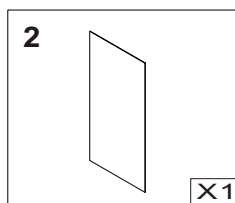
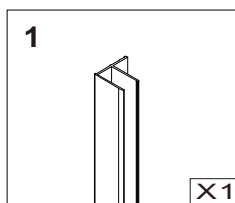
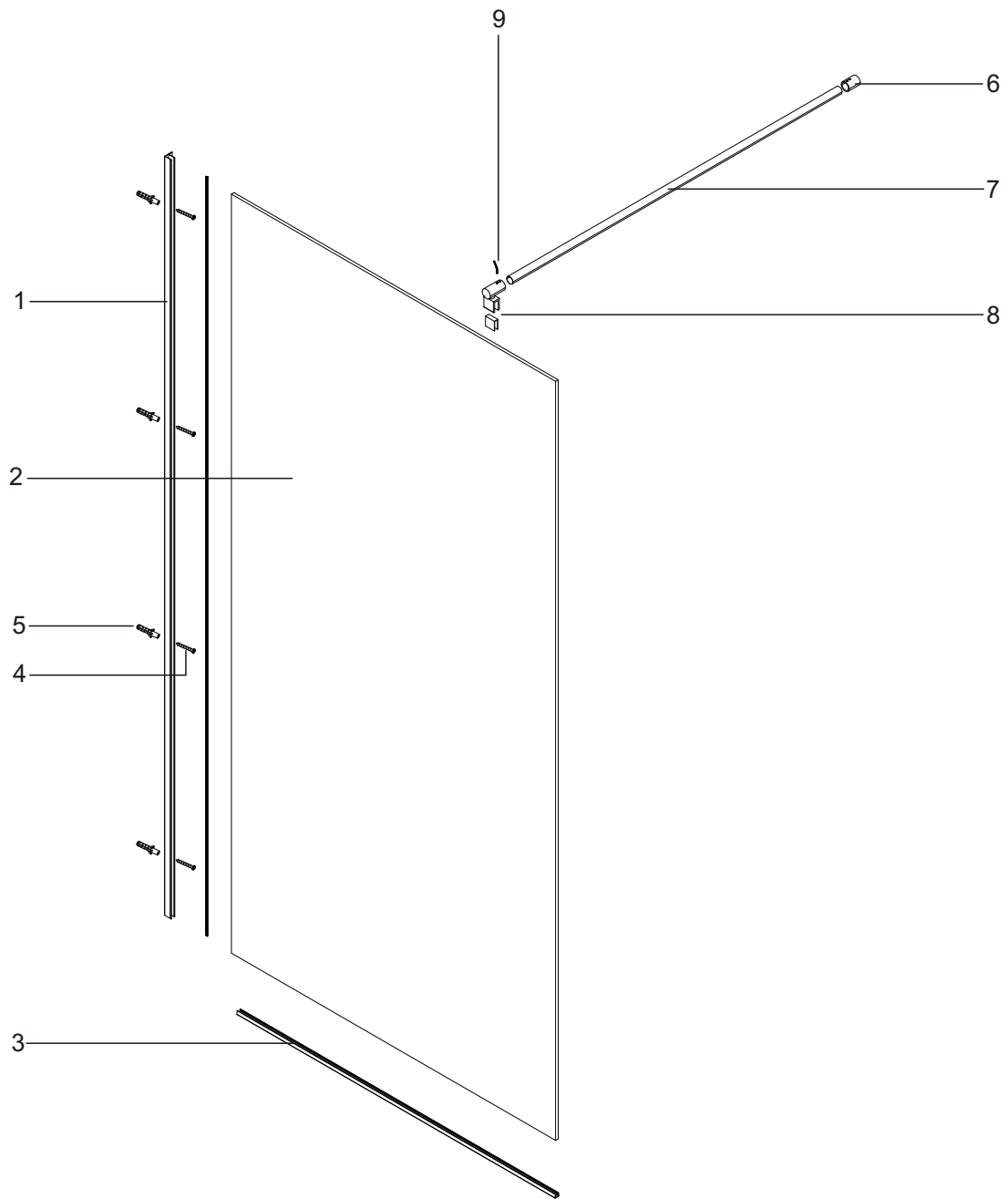

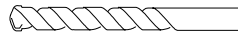
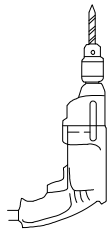
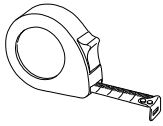

6mm

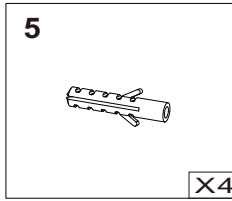
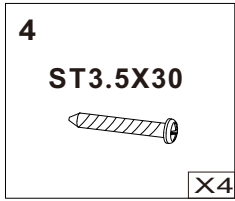
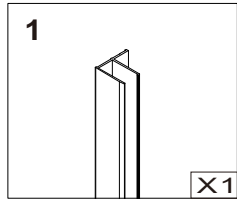
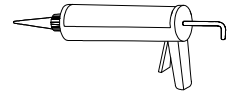
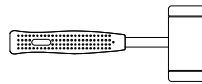

1

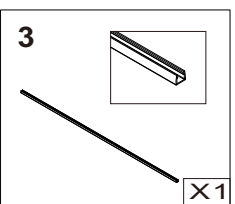
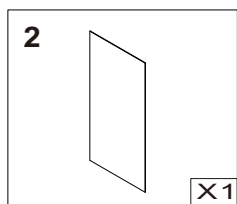
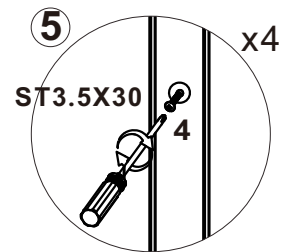
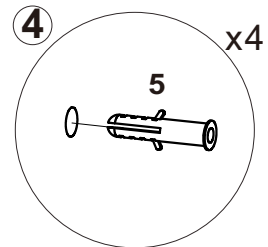
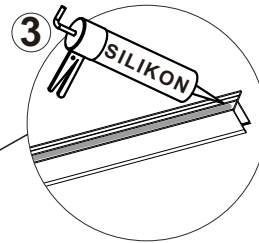
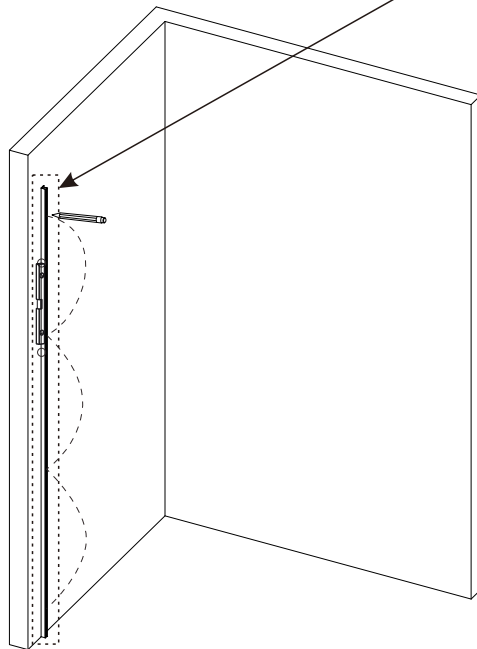
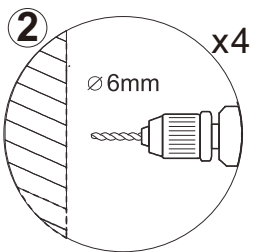
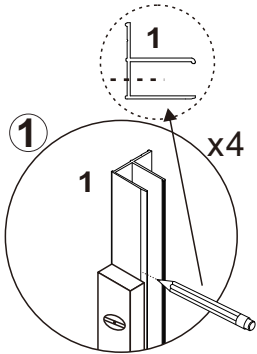

2

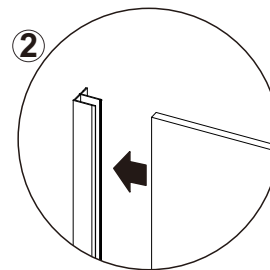
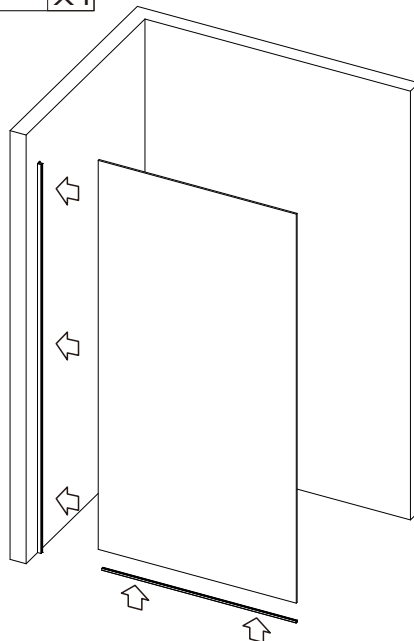
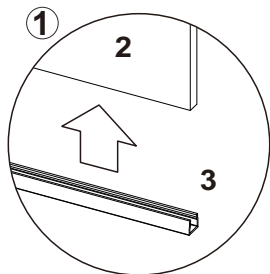

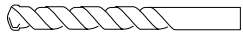
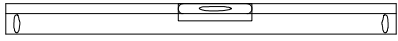

∅ 6mm

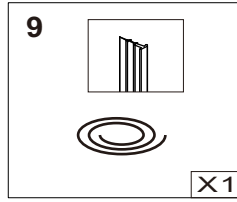
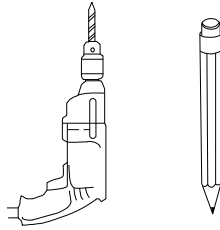

3

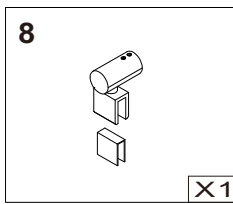
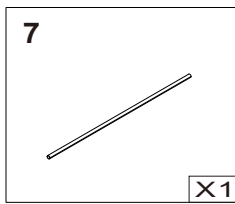
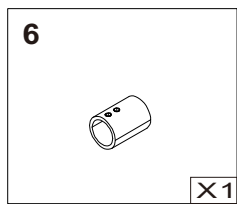
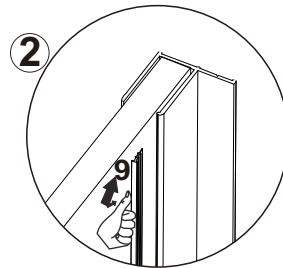
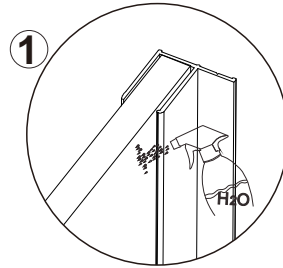
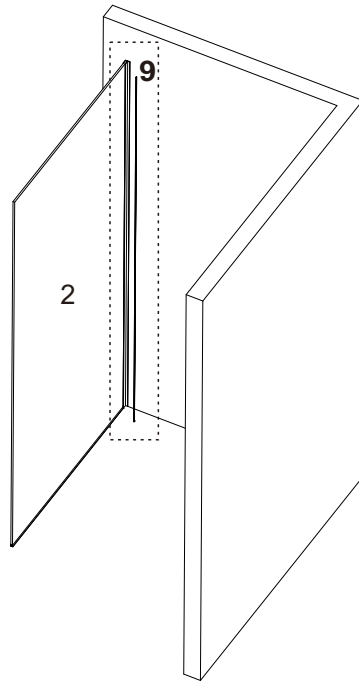

4

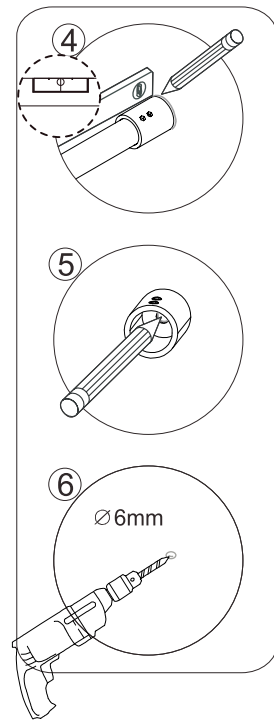
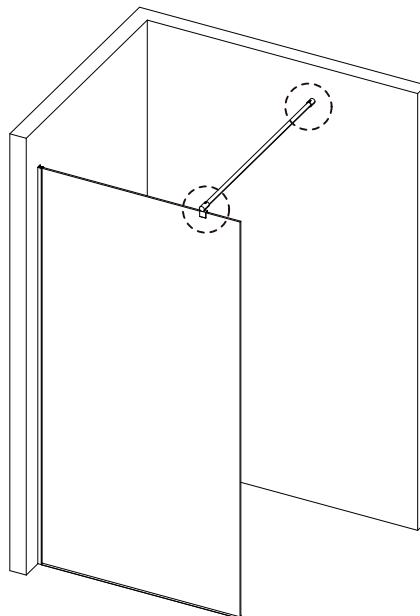
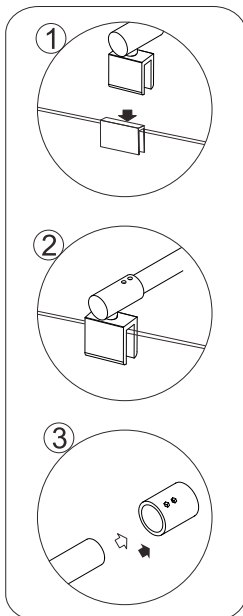

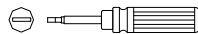
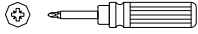
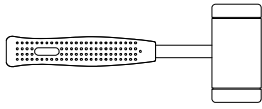

5

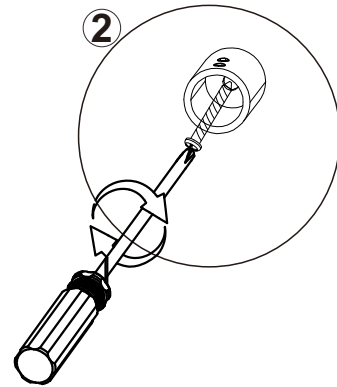
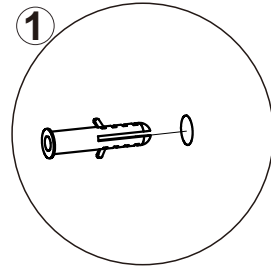
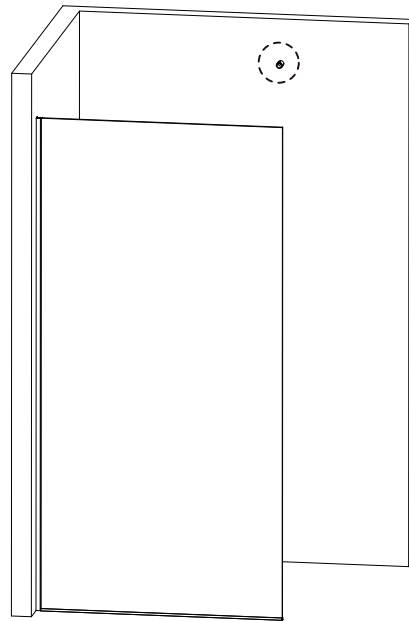
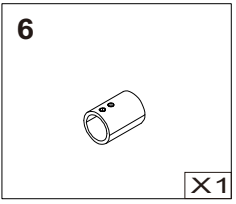
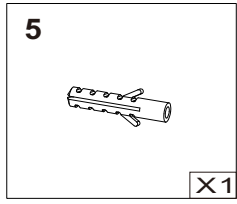
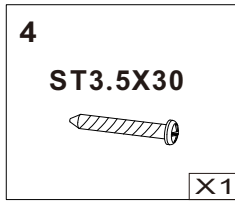

6

